

SPECIFICATIONS

Rated Current: 0.75AMP
 Contact Resistance: 20mΩ Max
 Withstand Voltage: 500V AC/DC
 Insulation Resistance: 1000MΩ Min
 Operation Temperature: -40°C to +105°C

Contact Material: Brass
 Contact Plating: Au or Sn Over Ni
 Insulator Material: Polyester (UL94V-0)
 Standard: LCP
 Max. Processing Temp: 230°C for 30-60 seconds
 (260°C for 10 seconds)

NO OF CONTACT	DIMENSIONS	
	A	B
10P	7.00	4.00
16P	10.00	7.00
20P	12.00	9.00
40P	22.00	19.0
64P	34.00	31.0

Ordering Information

3251 XX S XX X B K00 X 01

- No. of Pins: 10, 16, 20, 40, 64P
- Contact Plating: G0: Gold Flash, G1: 3U" Gold, G2: 5U" Gold, G3: 10U" Gold, G4: 15U" Gold, G5: 30U" Gold, S0: Gold Flash/Tin, SN: Tin
- Insulator Material Option: A=BK-PBT, C=BK-PA6T, D=BK-PA46, E=BK-PA9T, F=BK-LCP
- Packing: A=Troy, T=Tube, P=Tube+Cap, R=Reel+Cap

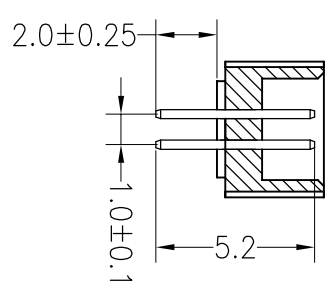
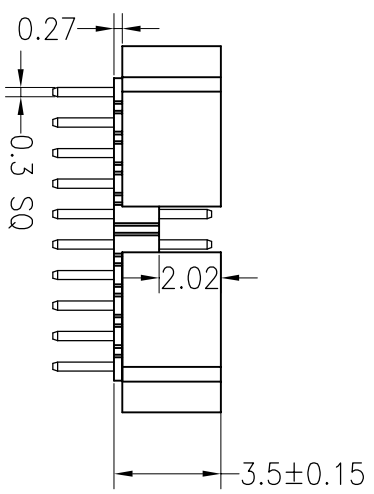
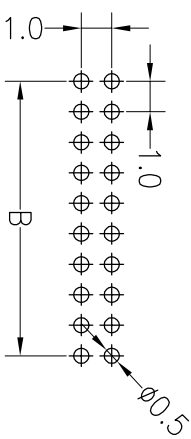
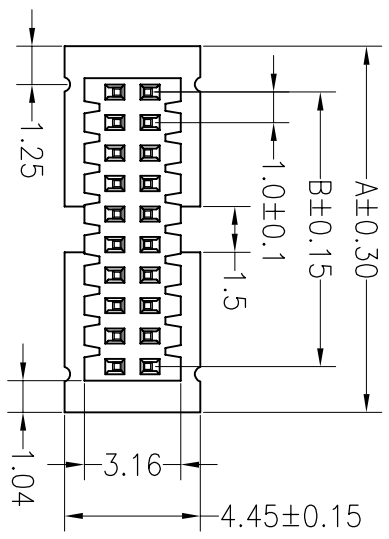

OPERATION		DRAW		SCALE		FIT		TITLE:	
DIM	TOL	ANGLE	APPROVE	UNIT	mm	SIZE	A4	PART NO.	3251XXSXXBK00X01
X.X	±0.30	X.XX	CHECK	Yiyusheng	18.08.20	1/1	1/1	1.0mm Box Header Npin H3.5 180°	
X.XXX	±0.10	X.XXX	CHECK						
±3°									
±3°									

BESTCONN(WUHAN) TECHNOLOGY CO.,LTD
<https://bsconnector.com/>

REV	DATE	MODIFICATION DESCRIPTION	CHANGE
A0	2018.08.20	NEW DRAWING	