

SPECIFICATIONS

Rated Current:1.0AMP
 Contact Resistance:20mΩ Max
 Withstand Voltage:500V AC/DC
 Insulation Resistance:1000MΩ Min
 Operation Temperature:-40°C to +105°C

Contact Material:Brass
 Contact Plating:Au or Sn Over Ni
 Insulator Material:Polyester(UL94V-0)
 Standard: PA6T
 Max. Processing Temp: 230°C for 30-60 seconds
 (260°C for 10 seconds)

Recommended P.C.B Layout(Top Side)
 (PCB BOARD TOLERANCE±0.05)

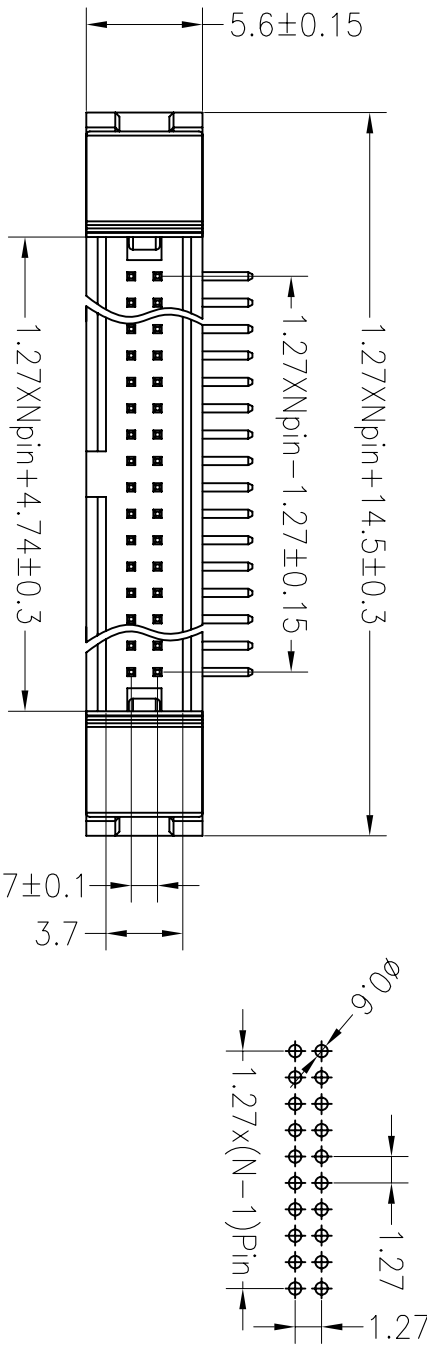

Ordering Information

3330 XX R XX X X S X 01

- No. of Pins 10--60
- Contact Plating
 G1:Gold Flash
 G2:1.5U" Gold
 G3:2U" Gold
 G4:3U" Gold
 G5:5U" Gold
 S0:Gold Flash/Tin
 SN:Tin
- Insulator Material Option
 A=BK-PBT
 C=BK-PA6T
 D=BK-PA46
 E=BK-PA9T
 F=BK-LCP
- Color Type
 B=Black
 G=Grey
- Packing
 O=PE Bag
 A=Troy
 T=Tube

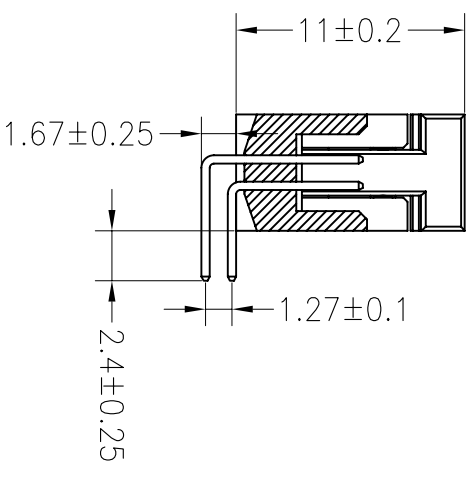
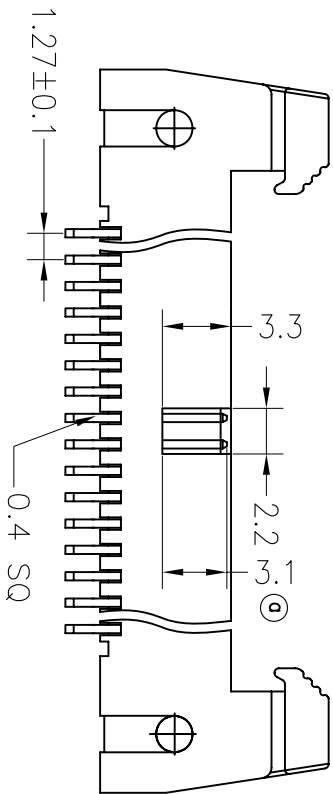

OPERATION		DRAW		SCALE		FIT		BESTCONN(WUHAN) TECHNOLOGY CO.,LTD https://bsconnector.com/	
X.X	±0.30			UNIT	mm				
A1	2016.01.19	2.8mm增加至3.1mm		CHECK		SIZE	A4	PART NO.	3330XXRXXXXX01
A0	2012.10.05	NEW DRAWING				SHEET	1/1	TITLE:	1.27DC2-Npin 90° L10.3/12.8
REV	DATE	MODIFICATION DESCRIPTION		CHANGE		PROJ.			
1									