



**SPECIFICATIONS**

Rated Current:1.5AMP  
 Contact Resistance:20mΩ Max  
 Withstand Voltage:500V AC/DC  
 Insulation Resistance:1000MΩ Min  
 Operation Temperature:−40°c to +105°c

Contact Material:Brass  
 Contact Plating:Au or Sn Over Ni  
 Insulator Material:Polyester(UL94V−0)  
 Standard: PA6T  
 Max.Processing Temp: 230°C for 30−60 seconds  
 (260°C for 5 seconds)

# Ordering Information

1320 12 XX X N XX R XXX X 01

No. of Pins 2\*1~2x40  
 Insulator Material Option  
 A=BK−PBT  
 C=BK−PA6T  
 D=BK−PA46  
 E=BK−PA9T  
 F=BK−LCP  
 Contact Plating  
 G0:Gold Flash  
 G1:1U" Gold  
 G2:1.5U" Gold  
 G3:2U" Gold  
 G4:3U" Gold  
 G5:5U" Gold  
 SO:Gold Flash/Tin  
 SN:Tin  
 Pin Length  
 Packing  
 A=Tray  
 T=Tube  
 O=Pe  
 R=Tape&Reel  
 P=Tube&Reel

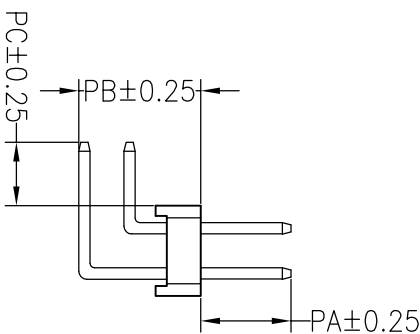
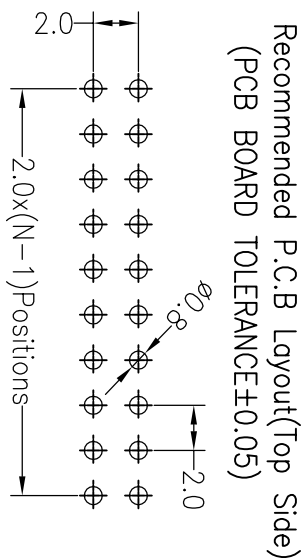
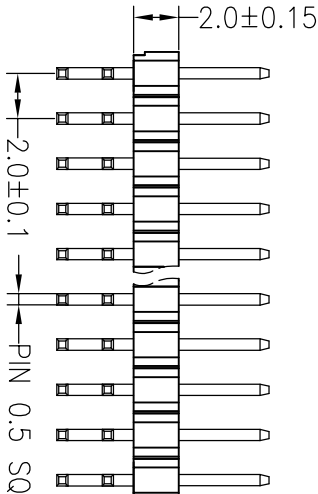
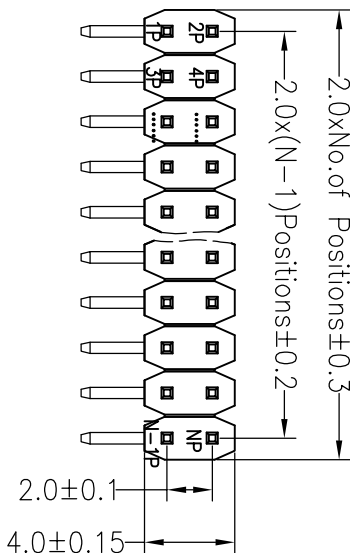

Dimension antitheses list					
ITEM	PA	PB	PC	L短	L长
Standard	4.00	5.40	2.80	10.50	14.50

**BESTCONN(WUHAN) TECHNOLOGY CO.,LTD**  
<https://bsconnector.com/>

OPERATION		DRAW		SCALE	FIT	PART NO.	
X.X	±0.30	YYuSheng	19.09.18	mm	A4	132012XXXXXXRXXXX01	
X.XX	±0.20	CHECK					
X:XXX	±0.10						
Angle	±3°	APPROVE					
DIM	TOL						
TITLE:		PROJ.		SHEET		1/1	
DATE		MODIFICATION DESCRIPTION		CHANGE		2.0PH 2xNpin H2.0mm 90°	
REV		NEW DRAWING		DATE		2019.09.18	